

DESIGN AND INSTALLATION GUIDE

PAROC® VECT WIRED MAT BLACKCOAT EI60
CIRCULAR



PAROC®

SYSTEM DEFINITION

System for fire protection to steel ventilation ducts assembled on-site

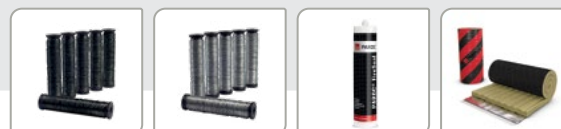
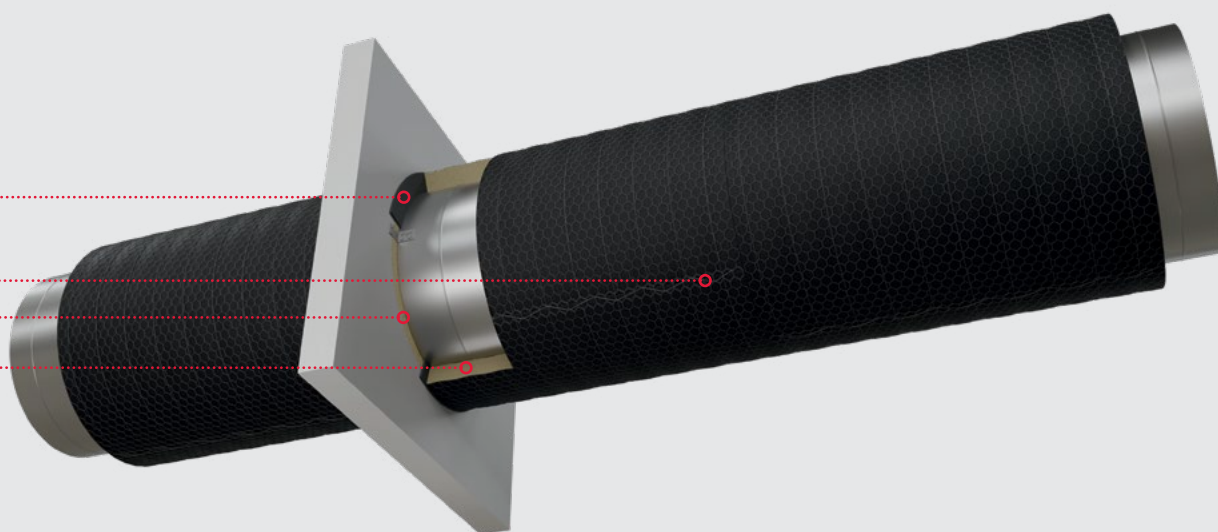

SYSTEM PARTS

PART NAME	PART DESIGNATION	TECHNICAL SPECIFICATION
Duct insulation	PAROC® Vect Wired Mat BlackCoat EI60	EN 14303; PAROC Declaration of Performance
Penetration seal gap filler	PAROC® Stonewool	Any unfaced PAROC® Stonewool, minimum density 60 kg/m ³ , reaction to fire class A2-s1,d0 or better, EN 14303 or EN 13162
Fire Sealant	PAROC® FireSeal	PAROC Technical Datasheet*
Wire	Steel wire	Steel wire; minimum thickness 0,7 mm; galvanized, oxidized, stainless steel or coated
Clips	C-clips or netting clips	Steel/netting clips; minimum thickness 0,7 mm; galvanized, oxidized, stainless steel or coated
Welding pins	Cuphead welding pins CD (capacitor discharge)	Shaft: Ø2,7 mm copper-coated mild steel, insulated with plastic sleeve under the head Shaft tip sharpness: any flattening or radius of the tip cannot exceed 0,5 mm Cuphead: Ø30 mm zinc-coated mild steel, insulated from the shaft side with paper washer

*System components are specified in detail in the PAROC Technical Datasheets.

! The system declared performance only applies if the specified components are used, the system is installed in accordance with the PAROC Installation Guide, and all the conditions of the PAROC Design Guide are met regarding specification of the ductwork to be insulated and wall/floor structures that the ductwork is penetrating. Parts, structural elements, and installation operations that are not specified in the PAROC documentation are assumed to follow manufacturers standards and standard practices. Installation operations shall be carried out by installers with an appropriate level of knowledge and experience in the field of insulating steel air ductwork using the technologies: taping, wire and steel mesh binding, capacitor discharge welding.

DESIGN RULES

This fire protection duct system is designed for circular ducts, horizontal and vertical, standard sizes to EN 1366-1, tested at standard conditions for fire inside the duct (3 m/s air flow rate) and -500 Pa for fire outside the duct.



THE FIRE PROTECTION SYSTEM CAN BE APPLIED TO CIRCULAR DUCTS THAT COMPLY WITH THE FOLLOWING PARAMETERS

- Tightness class D or higher according to EN 12237 and maximum 500 Pa overpressure and underpressure.
- Duct sections are made tight with EPDM gasket used between duct sections and connector coupling. The connector coupling is fixed into the duct section with self-drilling screws with 150 mm spacing, minimum 4,2 mm screw size, or by pressure-tight steel rivets with a minimum size of 3,2 x mm.
- Duct diameter should be a maximum size of 1000 mm.
- Horizontal ducts are suspended using clamps and pairs of steel threaded rod hangers, the two rods of each pair placed on the opposite sides of the duct. The tension in the hangers in cold conditions must not exceed 9 N/mm². The threaded rods are attached to the ceiling by anchoring elements with the proven loadbearing capacity to carry the insulated ductwork for the same or higher fire resistance time than the duct system in standard fire conditions (ISO 834 / EN 1363-1 standard fire curve).
- Horizontal installation: Distance between hangers should be a maximum of 1800 mm.
- Length of duct sections should be a maximum of 6000 mm.
- Position of hangers and insulation joints relative to duct joints: any.
- Vertical installation: Distance between floor levels / duct supports can be a maximum of 8x duct diameter, maximum 5 m.

THE DUCTS MAY PENETRATE

- Walls – flexible wall construction of plasterboards faced steel stud partition containing mineral wool insulation in the void, fire rated at a minimum of the same as or higher than the duct system, minimum wall thickness 100 mm. Reinforcing steel studs shall be applied in horizontal and vertical direction at all the edges of the aperture.
- Other types of walls – light aerated concrete, concrete, masonry, all with a minimum fire resistance rating the same as or higher than that of the duct system, minimum wall thickness 100 mm.
- Floors and decks – light aerated concrete with a minimum fire resistance rating the same as or higher than that of the duct system, minimum floor/deck thickness 100 mm.
- Other types of floors/decks – concrete, masonry, all with a minimum fire resistance rating the same as or higher than that of the duct system, minimum floor/deck thickness 100 mm.

PENETRATION SEAL THROUGH WALLS/FLOORS

- Maximum gap between the duct and the wall/floor is 30 mm.
- Duct is attached to the wall/floor using four steel L-angles, minimum size 50 x 50 x 35 x 2 mm and maximum size 105 x 80 x 90 x 2 mm (oriented so that the bracket will not extend further than the insulation thickness).
- In the wall, two L-angles are positioned on each side of the wall with angular spacing of 180°. The pairs of the L-angles are shifted by 90° on the opposite sides of the wall.
- On the floor, four L-angles are placed on the top with angular spacing of 90°.
- Each steel L-angle is screwed to the duct by two self-drilling screws with minimum size 4,2 mm, placed diagonally across the L-angle.
- Design of the penetration seal system is otherwise identical for all types of walls/floors.
- Gap filler: any unfaced PAROC® Stonewool, minimum uncompressed density 60 kg/m³, reaction to fire class A2-s1,d0 or better, tightly stuffed in the cavity to fill it completely and flush with wall/floor surfaces.
- Stone wool filler is covered by a layer of fire sealant 3-5 mm thick. The fire sealant layer may extend to adjacent surfaces of wall/floor.
- The edge surface of stone wool insulation facing the wall/floor/ceiling is glued with PAROC® FireSeal to the penetration and wall/floor/ceiling.

INSULATING LAYER ON THE DUCT SURFACES

- Insulation product PAROC® Vect Wired Mat BlackCoat EI60, nominal thickness 80 mm.
- Offset of longitudinal joints by a minimum of 100 mm.
- Fixing insulation to the duct – four optional methods of connecting the wire mesh joints:
 1. Wire mesh is twisted approximately each 150 mm.
 2. Wire mesh is sewn by wire with a minimum thickness of 0,7 mm.
 3. Wire mesh is connected with clips, approximately each 150 mm.
 4. Wire mesh is stitched by small steel wire loops with a minimum thickness of 0,7 mm, approximately each 150 mm.

Longitudinal joints of wire mesh must be connected using any of the methods above. Connecting transversal joints is optional. If transversal joints are twisted (method 1), the mesh wires can be twisted; never twist the perimeter wire.

Material of the wire mesh and wires: steel with any surface finishing or stainless steel.

As an additional measure, to further secure the installation, the insulation may be attached to the duct by welding pins. Pins must be placed a minimum of 50 mm from joints of the mats.

INSTALLATION PROCEDURE



INSTALLATION OF PENETRATION

Before starting the installation, the openings in the wall/floor must be checked if they are clean and following the design rules given in this document. Working temperature is a minimum of +10 °C.

1. Fill the gap tightly and completely with unfaced PAROC® Stonewool, minimum uncompressed density with 60 kg/m³, reaction to fire class A2-s0,d1 or better. The resulting surface of stone wool filling must be flush with both surfaces of the wall/floor.
2. Prime the surface of the stone wool filling and surrounding wall/floor surfaces with clean water.
3. Apply a continuous layer of fire sealant on both sides of the stone wool filler compressed in the gap, thickness 3 to 5 mm; this may extend to adjacent surfaces of wall/floor.
4. Make the fire sealant surface even and smooth with a wet brush or spatula.
5. Stabilise the duct by attaching steel L-angles (if not installed already).

Screws for fixing the L-angles to the wall/floor must be made of steel and be of an appropriate type for the wall/floor material. Two screws must be used to attach each L-angle to the wall/floor. Minimum size is 5 mm for aerated concrete, and 3,5 mm for lightweight partitions – screwed to the steel structure of the drywalls. They may include dowels or other type of anchors suitable for fire resistance of the duct.

BASIC RULES FOR HANDLING THE INSULATION MATS

- Mats must be handled with care to avoid damage to the insulation or facing.
- Unpack and unfold the mat on a flat surface, remove the plastic foil and shake the mat gently and let it rest for a minimum of 10 minutes, until it regains its original thickness and releases any tension due to packing compression.
- The insulation layer must have a uniform thickness; therefore, avoid too much stress or pinching fingers during product handling and installation.

The insulation material compensates surface irregularities of the duct through its material properties. Therefore cuts for L-angles or flanges are not required. Bends and T-joints can be insulated by cutting segments of the insulation material.

INSTALLATION OF MATS ON THE DUCT

Before installing the insulating layer, the ductwork must be checked if:

- It fulfils air tightness criteria.
- It is assembled according to design, with proper quality, without visible holes or gaps or mechanical damage.
- Duct joints are tight and properly fit together.
- All the sizes and components comply with this guide.
- Penetration seal is installed in compliance with this guide.

Mat length is calculated as: $3,14 \times (\text{steel duct diameter} + 2 \times \text{insulation thickness} + \text{addition for mat compression})$. Addition for mat compression is approximately 20 mm or a minimum 2% of the mat length. If the mat is too short to wrap the duct in a single piece, the correct final length can be made by connecting several pieces of the mat. Minimum size of any single piece of mat in any direction is 200 mm.



INSTALLATION OF MATS ON HORIZONTAL DUCT

1. Cut the mat to the correct length corresponding to the circumference of the duct, leaving a minimum of 100 mm extra facing and mesh for overlapping.
2. Wrap the insulation around the duct tightly, so that no gaps occur at the insulation joints.
3. First install the second mat, leaving the space on the duct between the second mat layer and wall -30 mm or a minimum 2% of actual size of the gap, to allow the first mat to be adequately compressed against the wall.



4. Install and stabilize the first mat adjacent to the wall. Unless the fire sealant is still wet, the wall surface must be primed with clean water and another layer of fire sealant applied to create a gluing layer for the insulation. Spread the fire sealant with a wet brush or spatula to make a soft layer approximately 1 mm thick. Immediately after, while the fire sealant is still wet, glue the insulation to the wall.





5. Place the following mats on the duct after one another compressing all the mats to the final installed width 20 mm or a minimum of 2% less than the original mat width.

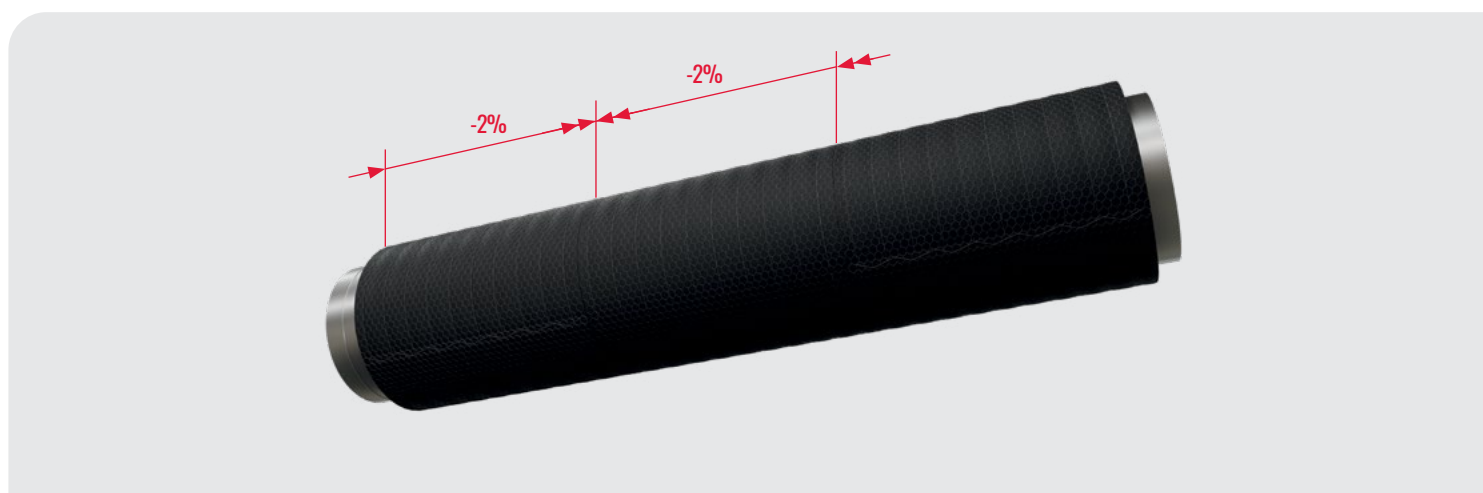

6. Place the remaining mats on the duct. Longitudinal joints of the adjacent mats are to be offset by a minimum of 100 mm. The last mat must be glued to the wall with the fire sealant following the principles of 4.
7. In places where suspension rods penetrate the insulation, make a cut in the insulation, up to where suspension rod will be placed; new joint will be created this way.
8. If there are any visible gaps between mats and walls, apply an appropriate amount of fire sealant therein so that the insulation edge is glued to the wall on all its edge area. Excess fire sealant needs to be removed.



INSTALLATION OF MATS ON VERTICAL DUCT

1. Cut the mat to the correct length corresponding to the circumference of the duct, leaving a minimum of 100 mm extra facing and mesh for overlapping.
2. Wrap the insulation around the duct tightly, so that no gaps occur at the joints.
3. Install the first mat adjacent to the floor/ceiling. Unless the fire sealant is still wet, the floor/ceiling surface must be primed with clean water and another layer of fire sealant applied to create a gluing layer for the insulation. Spread the fire sealant with a wet brush or spatula to make a soft layer approximately 1 mm thick. Immediately after, while the fire sealant is still wet, glue the insulation to the floor/ceiling.
4. Place the remaining mats on the duct after one another compressing all the mats to the final installed width 20 mm or a minimum of 2% less than the original mat width. Longitudinal joints of adjacent mats are to be offset by a minimum of 100 mm. The last top/bottom mat must be glued to the ceiling with PAROC® FireSeal following the principles of 3.

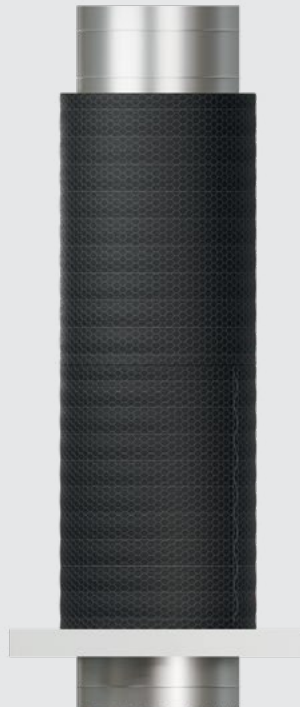

5. If there are any visible gaps between the mats and floor/ceiling, apply an appropriate amount of fire sealant therein so that the insulation edge is glued to the floor/ceiling on all its edge area. Excess fire sealant needs to be removed.



SECURING THE INSULATION LAYER ON THE DUCTWORK

Fixing insulation to the duct – four optional methods of connecting the wire mesh joints:

1. Twist the wires in longitudinal joints approximately each 150 mm. Connecting transversal joints is optional. If transversal joints are twisted (method 1), the mesh wires can be twisted; never twist the perimeter wire.
2. Sew the longitudinal (optionally also transversal) joints by wire with a minimum thickness of 0,7 mm.
3. Connect the longitudinal (optionally also transversal) joints with clips, approximately each 150 mm.
4. Stitch the longitudinal (optionally also transversal) joints by small steel wire loops with a minimum thickness of 0,7 mm, approximately each 150 mm.

GUIDANCE ON CUP HEAD PIN WELDING

To deliver the required fire performance of insulated duct systems, the quality of components and capacitor discharge welding process are crucial. The following parameters are critical to deliver the required weld quality. Good weld quality must be tested prior to attaching insulation on the duct.

Test of the weld quality

- Weld a minimum of five pins to the same material, steel thickness, and surface as the insulated duct.
- Visually inspect the weld. The pin tip should be properly melted with the steel sheet, without any visible reduction of pin diameter at the weld or radial burn patterns from the weld.
- Bend the pin using a pair of pliers until the pin breaks. The pin must not detach from the steel sheet at the weld, but from slightly above. The weld must be stronger than the pin shaft.
- Repeat the test whenever the weld parameters change (pin type, steel thickness) or whenever there is a doubt about the weld quality based on sensory perceptions during welding.

NOTE: As certain conditions to achieve good weld are affected by the insulation product (points 4 and 5 below), it is recommended to perform this test with the insulation product and remove it before testing the weld quality by bending of pins.

Conditions to achieve good weld quality

1. Sharp tip of the pin; any flattening or radius of the tip cannot exceed 0,5 mm.
2. Optimal setting of the welding machine
 - Voltage
 - Spring tension in the hand tool
3. Avoiding excess manual force on the pin during welding. There must be only light touch of the pin to the steel duct surface, and when the hand tool is triggered, the pin must only be pushed against the steel duct surface by the spring force in the hand tool.
4. Sufficient pin length so that there is minimum 3 mm clearance between the insulation surface and the pin head before welding.
5. Avoiding any stray currents and additional electrical resistance for the current flowing between the pin and the steel duct surface during the welding.
 - Place the negative electrode on the same duct segment where welding is performed.
 - Keep both electrodes clean and make sure there is good contact between the pin and the hand tool and between the negative electrode clip and the duct surface.

PAROC SALES OFFICES AND CONTACTS

Headquarter / Finland

Paroc Group Oy / Paroc Oy Ab
P.O. Box 240
FI-00181 Helsinki, Finland
Energiakuja 3
Phone: +358 46 876 8000



Estonia

AS Paroc
Pärnu mnt 158
EE-11317 Tallinn, Estonia
Tel. +372 651 8100



Denmark

Paroc Danmark Filial af PAROC AB
Helsingør Erhvervspark A/S
H P Christensensvej 1
DK-3000 Helsingør
Tel. +45 49 12 10 00



Latvia

SIA Paroc
Vienības gatve 109
Riga, LV-1058, Latvia
Tel. +371 7 339053



Germany / Switzerland / Austria

Paroc GmbH
Heidenkampsweg 51
D-20097 Hamburg, Germany
Tel. +49 40 33 49 60000



CONTACT US

Lithuania

UAB Paroc
Savanoriu 124
03153 Vilnius, Lithuania
Tel. +370 5 2740 000



Norway

Paroc AB Norge
Rosenholmveien 25
NO-1414 Trollåsen, Norway
Tel. +47 22 64 59 00 / 01



Poland

Paroc Polska sp. z o.o.
ul. Gnieźnińska 4
62-240 Trzemeszno, Poland
Tel. +48 61 468 21 90



Sweden

Paroc AB
SE-541 86 Skövde, Sweden
Visiting address: Bruksgatan 2
Tel. +46 500 469 000



The United Kingdom / Ireland

Owens Corning Insulation (UK) Ltd
31-35 Kirkby Street
London EC1N 8TE
The United Kingdom



CONTACT US

Disclaimer

The information relating to the products and systems contained in this communication ("Information") is accurate and reliable to the best of our knowledge as of its date issued and is subject to change without prior notice. No guarantee of accuracy is given or implied.

Since Paroc has no control over installation workmanship, accessory materials or conditions of application, no express or implied warranty of any kind, including those of merchantability or fitness for a particular purpose or course of performance or usage of trade, is made as to the performance of an installation containing Paroc products.

While the Information in this communication may relate to the technical application of certain Paroc products, it is in no event to be considered as technical advice on the basis of which Paroc may incur any liability.

User is solely responsible for determining whether a Paroc product is fit for a particular purpose and suitable for user's method of use or application.

Users of the provided Information assume full responsibility for all concept/design decisions made relating to the suitability of use.

Users must rely on their own judgment or that of a concept/design professional when determining how to best apply the data provided.

Users agree that Paroc is under no obligation to provide additional details, testing or test data on its behalf.

Liability of Paroc, if any, is strictly limited to replacement of product. In no event shall Paroc be liable for any other damages arising because of product failure, whether incidental, special, consequential or punitive, regardless of the theory of liability upon which any such damages are claimed.

July 2025
1270TIEN0625
© Paroc 2025

