

DESIGN AND INSTALLATION GUIDE

PAROC® VECT SLAB BLACKCOAT EI60
RECTANGULAR EI 60 S



PAROC®

SYSTEM DEFINITION

System for fire protection of steel ventilation ducts assembled on-site

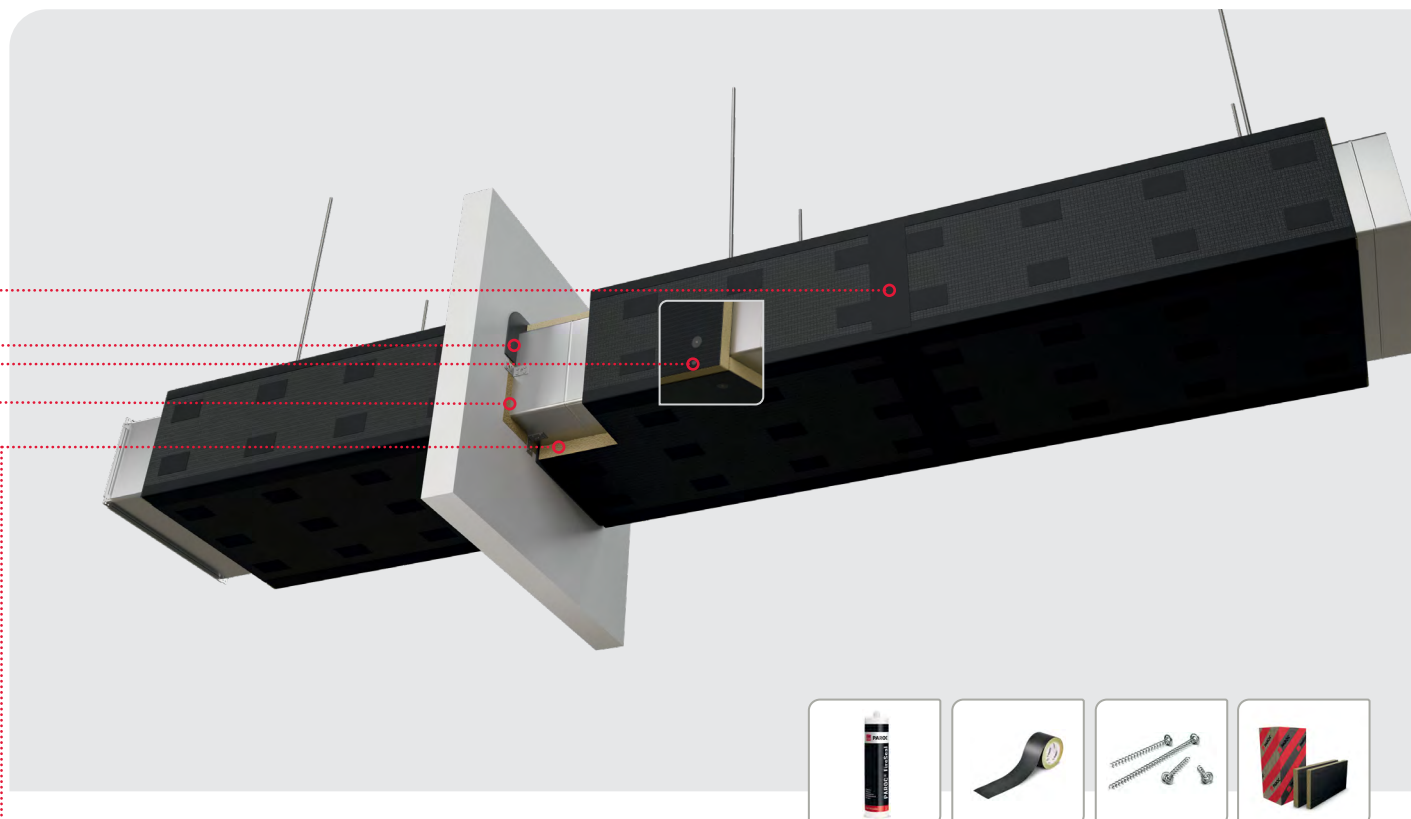

SYSTEM PARTS

PART NAME	PART DESIGNATION	TECHNICAL SPECIFICATION
Duct insulation	PAROC® Vect Slab BlackCoat EI60	EN 14303; PAROC Declaration of Performance; maximum slab size 1200 mm x 600 mm
Penetration seal gap filler	PAROC® Stonewool	Any PAROC® Stonewool, unfaced, minimum density 60 kg/m ³ , reaction-to-fire class A2-s1,d0 or better, EN 14303 or EN 13162
Fire Sealant	PAROC® FireSeal	PAROC Technical Datasheet*
Adhesive tape	PAROC® BlackCoat Tape	PAROC Technical Datasheet*
Fire springs	PAROC® Fire Spring	PAROC Technical Datasheet* Minimum length 140 mm.
Welding pins	Cuphead welding pins CD (capacitor discharge)	Shaft: Ø2,7 mm copper-coated mild steel, insulated with plastic sleeve under the head Shaft tip sharpness: any flattening or radius of the tip cannot exceed 0,5 mm Cuphead: Ø30 mm mild steel

*System components are specified in detail in the PAROC Technical Datasheets.

! The system declared performance only applies if the specified components are used, the system is installed in accordance with the PAROC Installation Guide, and all the conditions of the PAROC Design Guide are met regarding specification of the ductwork to be insulated and wall/floor structures that the ductwork is penetrating. Parts, structural elements, and installation operations that are not specified in the PAROC documentation are assumed to follow manufacturers standards and standard practices. Installation operations shall be carried out by installers with an appropriate level of knowledge and experience in the field of insulating steel air ductwork using the technologies: taping, wire and steel mesh binding, capacitor discharge welding.

DESIGN RULES

This fire protection duct system is designed for rectangular ducts, horizontal and vertical, standard sizes to EN 1366-1, tested at standard conditions for fire inside the duct (3 m/s air flow rate) and -500 Pa for fire outside the duct.



THE FIRE PROTECTION SYSTEM CAN BE APPLIED TO RECTANGULAR DUCTS THAT COMPLY WITH THE FOLLOWING PARAMETERS

- Tightness class C or higher according to EN 1507 and maximum 500 Pa overpressure and underpressure.
- The duct cross-section shall have a maximum width of 1250 mm and a maximum height of 1000 mm.
- The duct sections are made tight with a polymeric rubber gasket 5 x 15 mm used between the duct sections (flanges).
- Flanges: 20 mm height, joined with four bolts and nuts placed in the flange corners.
- The flanges are held together by C-profiles on all duct sides.
- Connection of flange to sheet steel: integrated, spot welded, screwed, riveted, or cold-pressed.

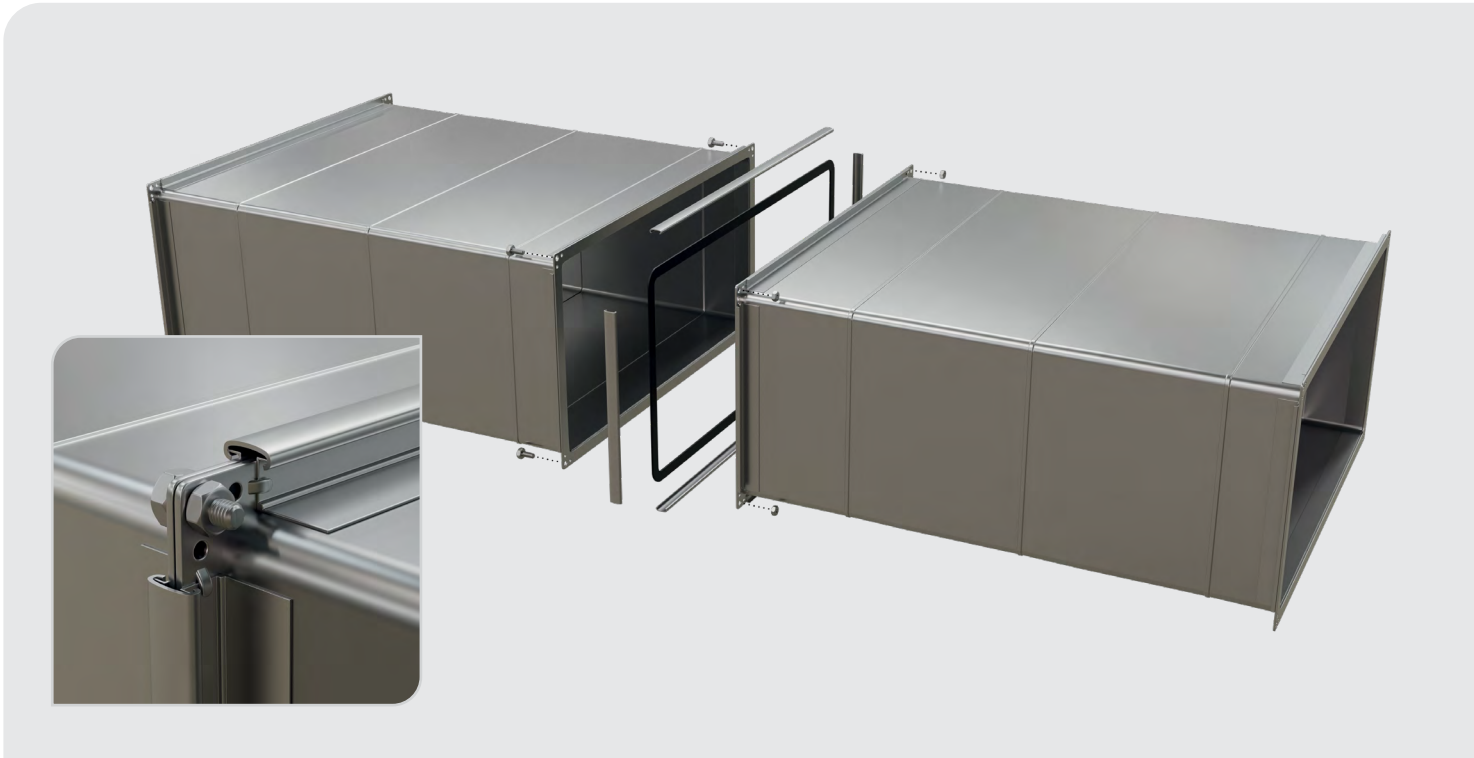



- The duct sections can be equipped with stiffeners. The stiffeners consist of:
 - steel pipes with a minimum external diameter of 16 mm and a minimum wall thickness of 2 mm;
 - washers with a diameter of minimum 70 mm on one or both sides of the steel sheet;
 - threaded rods with nuts at both ends of the pipe, minimum size M8; or steel dowels (anchors) and screws at both ends of the pipe, minimum size M8.
- Stiffener positions: as recommended by the duct manufacturers.
- Horizontal ducts are suspended on supporting profiles and pairs of steel threaded-rod hangers, with the two rods of each pair placed on the opposite sides of the duct. The tension in the hangers in cold conditions must not exceed 9 N/mm². The threaded rods are attached to the ceiling by anchoring elements with the proven loadbearing capacity to carry the insulated ductwork for the same or higher fire resistance time than the duct system in standard fire conditions (ISO 834 / EN 1363-1 standard fire curve).



- The maximum length of the duct segments is 1500 mm.
- Horizontal installation: The maximum distance between hangers is 1500 mm.
- Position of hangers relative to duct joints: 0–200 mm.
- Position of insulation slab joints relative to duct joints and hangers: any.
- Suspension profile: steel L-profile 30 x 30 x 3 mm.
- Vertical installation: The distance between floor levels / duct supports shall not exceed eight times the smallest side of the duct, with a maximum of 5 m.



THE DUCTS MAY PENETRATE

- Walls – flexible wall construction of plasterboard faced steel stud partition containing mineral wool insulation in the void, fire rated at a minimum of the same as or higher than the duct system, minimum thickness 95 mm. Reinforcing steel studs shall be applied in horizontal and vertical direction at all edges of the aperture.
- Other types of walls – light aerated concrete, concrete, masonry, all with a minimum fire resistance rating the same as or higher than that of the duct system, minimum thickness 95 mm.
- Floors – light aerated concrete with a minimum fire resistance rating the same as or higher than that of the duct system, minimum floor thickness 100 mm.
- Other types of floors – concrete, masonry, all with a minimum fire resistance rating the same as or higher than that of the duct system, minimum floor thickness 100 mm.

PENETRATION SEAL THROUGH WALLS/FLOORS – GAP FILLED WITH PAROC® STONEWOOL

- The maximum gap between the duct and the wall/floor is 30 mm.
- The duct is attached to the wall/floor using steel L-angles, minimum size 50 x 50 x 35 x 2 mm and maximum size 105 x 70 x 90 x 2 mm (oriented so that the L-angle will not extend further than the insulation thickness).
- In the wall, the L-angles are positioned on each side of the wall with the spacing of a maximum of 150 mm, and with the distances between the L-angles and the duct edges of a maximum of 150 mm.
- On the floor, the L-angles are positioned on top floor surface only, with the spacing of a maximum of 150 mm, and with the distances between the L-angles and the duct edges of a maximum of 150 mm.
- Each steel L-angle is screwed to the duct by two self-drilling screws with a minimum size of 4,2 mm, placed diagonally across the L-angle.
- The design of the penetration seal system is otherwise identical for all types of walls/floors.
- Gap filler: any unfaced PAROC® Stonewool, minimum uncompressed density 60 kg/m³, reaction-to-fire class A2-s1,d0 or better, tightly stuffed in the cavity to fill it completely and flush with wall/floor/ceiling surfaces.
- The stone wool filler is covered by a layer of fire sealant 3–5 mm thick that may extend to the adjacent surfaces of the wall/floor/ceiling. An additional layer of the fire sealant approximately 1 mm thick is applied to the interface between the stone wool insulation and the wall/floor/ceiling if the insulation is applied after the first layer of the fire sealant has dried out.

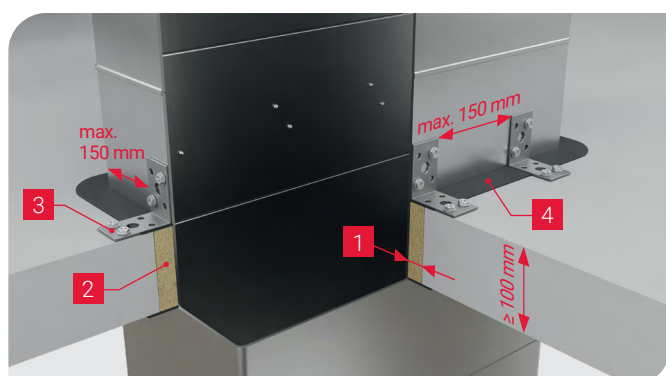
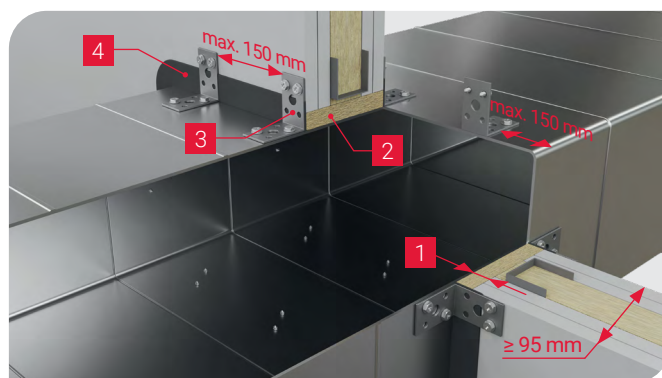
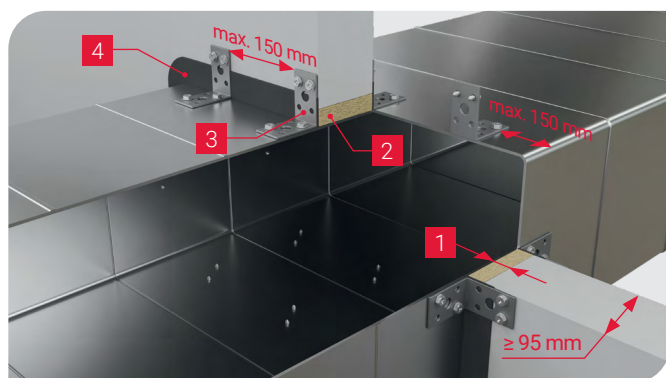

1. Max. gap 30 mm
2. Gap filler, PAROC® Stonewool
3. Steel L-angles, min. size 50 x 50 x 35 x 2 mm
4. PAROC® FireSeal



PENETRATION SEAL THROUGH FLOORS – ZERO DISTANCE BETWEEN THE CAST-IN CONCRETE AND THE STEEL DUCT

If the gap between the uninsulated steel duct and the edges of the opening in a floor is larger than 30 mm, it can be cast with concrete. The thickness of the concrete layer is a minimum of 100 mm.

The concrete is cast on a board supporting the concrete from the bottom side of the floor. The supporting board may be

- Used as temporary formwork and removed after the cast-in portion of the floor is completed – in that case, the reaction-to-fire class of the board is irrelevant.
- Left in place as a permanent part of the floor – in that case, its reaction-to-fire class shall be A1 or A2-s1,d0.

The penetration seal of ducts passing through hollow concrete floors can be made only if the gap between the duct surface and the edge of the opening is a minimum of 100 mm. In this case, the thickness of the concrete layer is the same as that of the surrounding floor.

Use of reinforcements within the floor opening is optional. PAROC takes no responsibility for loadbearing properties of the floor.

The duct is attached to the floor using steel L-angles, which are positioned approximately at the mid-depth of the floor.

- The minimum sizes of the L-angles: width 35 mm, thickness 2 mm, depth 30 mm, height 50 mm. The height may extend above the floor; it is useful if there is no access to screw the L-angle to the duct inside the floor opening.
- Each steel L-angle is screwed to the duct by two self-drilling screws with a minimum size of 4,2 mm, placed diagonally across the L-angle.
- The duct dimensions shall comply with the following limits: the maximum side length shall not exceed 1000 mm, and the maximum perimeter shall not exceed 2500 mm.
- The L-angles are positioned approximately at the mid-thickness of the floor, oriented upward, with a maximum spacing of 150 mm between the L-angles and from the edges of the duct.
- A layer of the fire sealant approximately 1 mm thick is applied to the interface between the stone wool insulation and the floor/ceiling.

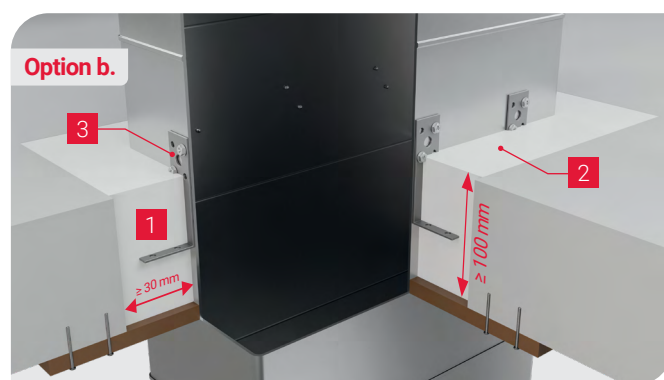
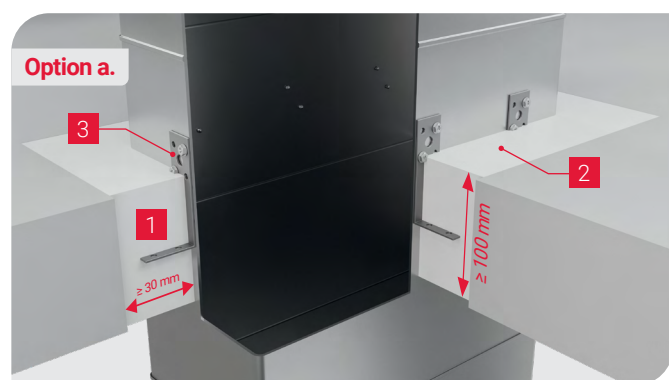

1. Min. gap 30 mm
2. Cast-in concrete
3. Steel L-angles, min. size 35 x 50 x 30 x 2 mm



INSULATING LAYER ON THE DUCT SURFACES

- Insulation product PAROC® Vect Slab BlackCoat EI60, nominal thickness 70 mm.
- Optionally, the slab joints (including any pinching of insulation, welding pin cupheads, and penetrations) may be taped, to provide a diffusion-resistant surface, using self-adhesive PAROC® BlackCoat Tape with a maximum width of 110 mm.

The insulation is attached to all vertical surfaces of the ducts and on the bottom horizontal or inclined surfaces with welding pins with a minimum diameter of 2,7 mm, a minimum head/washer diameter of 30 mm, and of appropriate length (depending on the real insulation thickness and duct surface geometry) to create a tight connection of insulation to the duct, not causing compression of stone wool in excess of 10%. For the top horizontal and inclined surfaces, welding pins are optional. The maximum distance between the welding pins is 350 mm in any direction. The distance between the welding pins and the slab edges is 50 mm to 100 mm. The maximum distance between the welding pins and the duct edges is 50 mm.

The corner joints of the insulation slabs are secured with fire springs with a minimum length of 140 mm. The maximum distance between the fire springs is 350 mm. The distance between the fire springs and the slab edges is 50 mm to 100 mm. The fire springs are positioned approximately at the mid-thickness of the slab (35 mm from the slab surface).

INSTALLATION PROCEDURE

Before starting the installation, ensure that the wall or floor openings are clean and comply with the design rules in this document.



INSTALLATION OF THE PENETRATION – GAP FILLED WITH PAROC® STONEWOOL

1. Fill the gap tightly and completely with unfaced PAROC® Stonewool. The resulting surface of stone wool filling must be flush with both surfaces of the wall/floor.
2. Prime the surface of the stone wool filling and surrounding wall/floor surfaces with clean water.
3. Apply a continuous layer of fire sealant on both sides of the stone wool filler compressed in the gap, thickness 3 to 5 mm; this may extend to adjacent surfaces of wall/floor.
4. Make the fire sealant surface even and smooth using a wet brush or spatula.
5. Stabilize the duct by attaching steel L-angles (if not installed already).

Screws used to fix the L-angles to the wall/floor shall be made of steel and be of a type appropriate for the wall/floor material. Two screws shall be used to attach each L-angle to the wall/floor. The minimum size is 5 mm for aerated concrete, and 3,5 mm for lightweight partitions – screwed to the steel structure of the drywalls. They may include dowels or other type of anchors suitable for fire resistance of the duct.

INSTALLATION OF THE PENETRATION – ZERO DISTANCE BETWEEN THE CAST-IN CONCRETE FLOOR AND THE STEEL DUCT USING A SUPPORTING BOARD AS TEMPORARY FORMWORK

1. Install the board that supports the concrete on the bottom surface of the floor.
2. Attach the steel L-angles to the duct.
3. Pour the concrete into the gap between the floor and the steel duct and let it dry out and harden.
4. Remove the supporting board.

INSTALLATION OF THE PENETRATION – ZERO DISTANCE BETWEEN THE CAST-IN CONCRETE FLOOR AND THE STEEL DUCT USING A NON-COMBUSTIBLE SUPPORTING BOARD AS A PERMANENT PART OF THE FLOOR

1. Install the board that supports the concrete on the bottom surface of the floor.
2. Attach the steel L-angles to the duct.



BASIC RULES FOR HANDLING THE INSULATION SLABS

- The slabs must be handled with care to avoid damage to insulation or facing.
- The insulation layer must have a uniform thickness; therefore, avoid too much stress or pinching fingers during product handling and installation.

Cuts for brackets or flanges must be done with due care and precision, in order not to remove more insulation material from the grooves and cut-outs than necessary. Bends and T-joints can be insulated by cutting segments of the insulation material.

INSTALLATION OF THE SLABS ON THE DUCT

Before installing the insulating layer, ensure that:

- The ductwork fulfils air tightness criteria.
- the ductwork is assembled according to design, with proper quality, without visible holes or gaps or mechanical damage.
- The duct joints are tight and properly fit together.
- All the sizes and components comply with this guide.
- The penetration seal is installed in compliance with this guide.

The minimum size of any single slab in any direction is 200 mm.



INSTALLATION OF THE SLABS ON A HORIZONTAL DUCT

1. Cut the slabs to the correct sizes.
2. First install the second slab on vertical duct sides, leaving the space on the duct between the second slab and the wall, to allow the first set of slabs to be adequately compressed against the wall. Following the same principle, install the second set of slabs on the bottom and top sides of the duct.

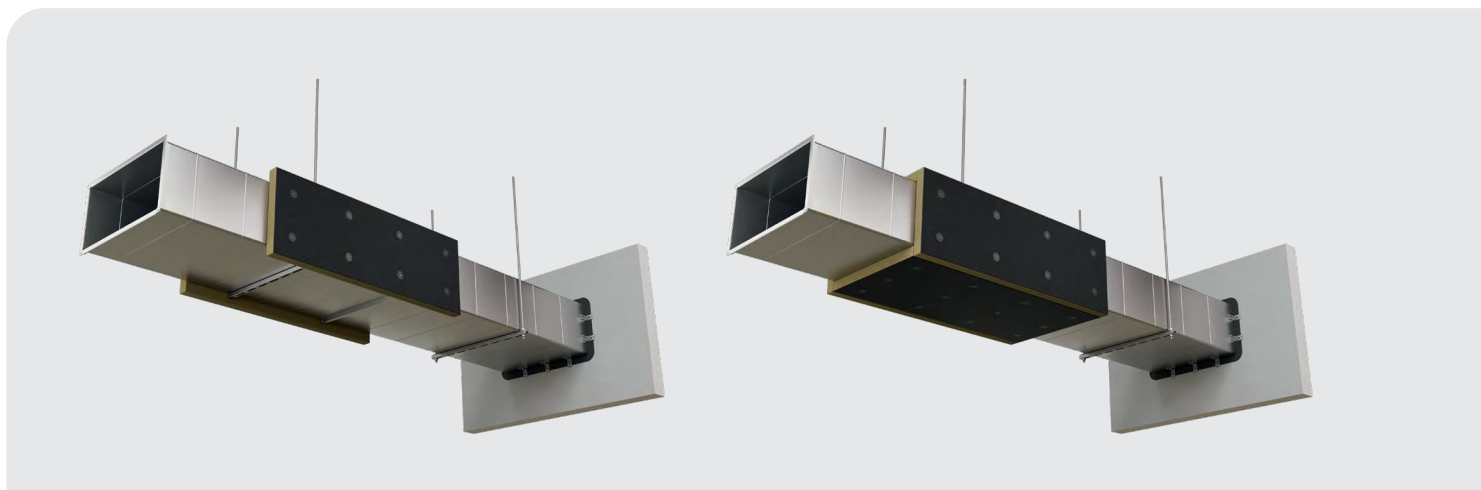

3. Install the first set of slabs adjacent to the wall in the same order: vertical sides, bottom, and top of the duct. Unless the fire sealant is still wet, the wall surface must be primed with clean water and another layer of fire sealant applied where the edge of the insulation will touch the wall: spread the fire sealant with a wet brush or spatula to make a soft layer approximately 1 mm thick. Immediately after, while the fire sealant is still wet, compress the insulation against the wall.





4. Place the following sets of slabs on the duct after one another. The last set of slabs must be compressed against the wall with the fire sealant applied following the principles of 3.
5. Where suspension rods or flanges penetrate the insulation, cut grooves or rabbets with maximum depth of 20 mm into the insulation prior to installing.
6. Check if all welding pins have been attached correctly, and install fire springs to reinforce the corner joints of the slabs.

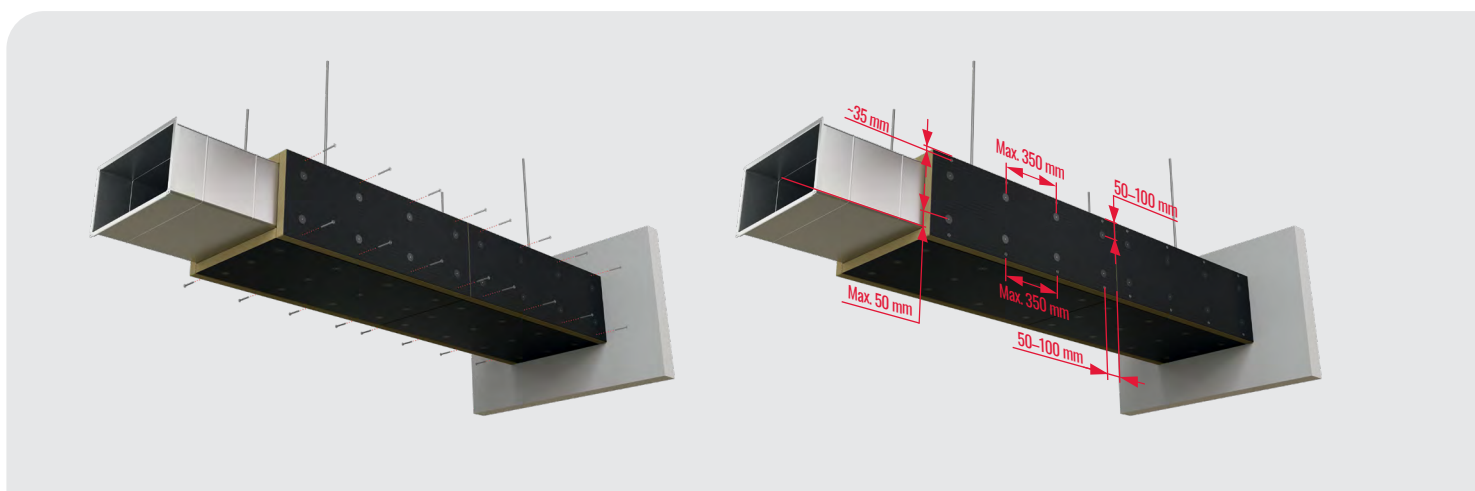

7. To reduce the risk of condensation (optional): carefully tape all joints, head pins, and fire springs with PAROC® BlackCoat Tape; pay attention to centrally positioning the tape in all directions.

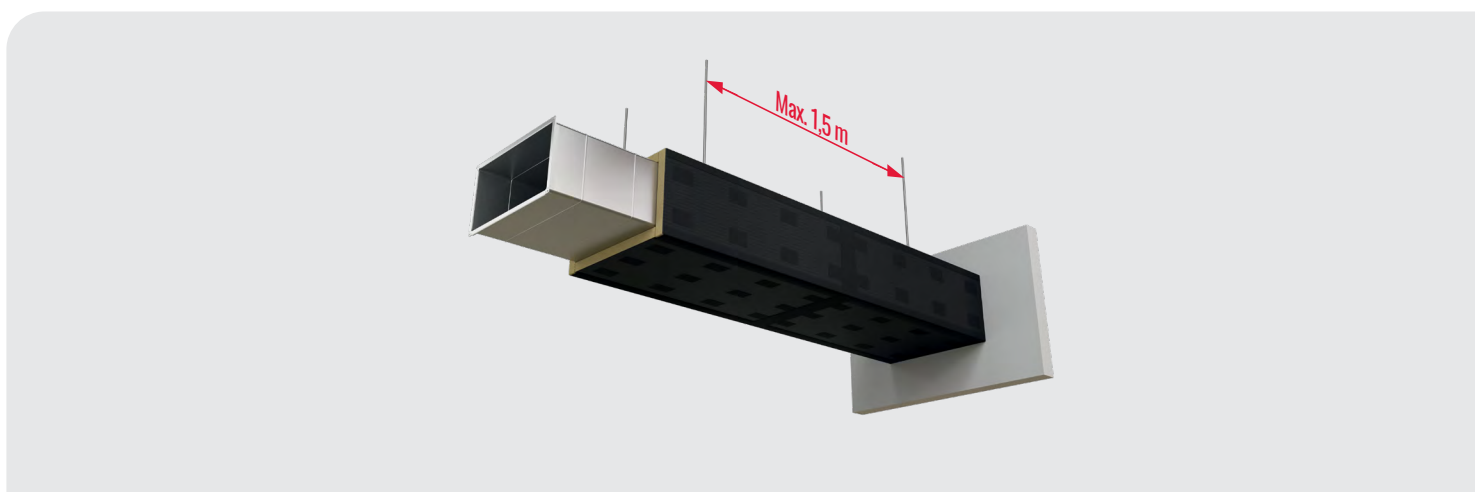

8. If there are any visible gaps between the slabs and the walls, apply an appropriate amount of fire sealant therein. Excess fire sealant needs to be removed.



INSTALLATION OF THE SLABS ON A VERTICAL DUCT

1. Cut the slabs to the correct sizes.
2. Install the first set of slabs adjacent to the floor/ceiling. Unless the fire sealant is still wet, the floor/ceiling surface must be primed with clean water and another layer of fire sealant applied where the edge of the insulation will touch the floor/ceiling: spread the fire sealant with a wet brush or spatula to make a soft layer approximately 1 mm thick. Immediately after, while the fire sealant is still wet, compress the insulation against the floor/ceiling.
3. Place the following sets of slabs on the duct after one another. The last top/bottom set of slabs must be compressed against the ceiling/floor with the fire sealant applied following the principles of 2.
4. Where flanges penetrate the insulation, cut grooves or rabbets with maximum depth of 20 mm into the insulation prior to installing.
5. Check if all welding pins have been attached correctly, and install fire springs to reinforce the corner joints of the slabs.

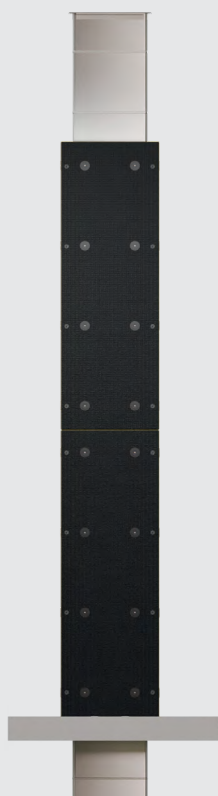

6. To reduce the risk of condensation (optional): carefully tape all joints, head pins, and fire springs with PAROC® BlackCoat Tape; pay attention to centrally positioning the tape in all directions.
7. If there are any visible gaps between the slabs and the floor/ceiling, apply an appropriate amount of fire sealant therein. Excess fire sealant needs to be removed.



GUIDANCE ON CUP HEAD PIN WELDING

To deliver the required fire performance of insulated duct systems, the quality of components and capacitor discharge welding process are crucial. The following parameters are critical to deliver the required weld quality. Good weld quality must be tested prior to attaching insulation on the duct.

Test of the weld quality

- Weld a minimum of five pins to the same material, steel thickness, and surface as those of the insulated duct.
- Visually inspect the weld. The pin tip should be properly melted with the steel sheet, without any visible reduction of pin diameter at the weld or radial burn patterns from the weld.
- Bend the pin using a pair of pliers until the pin breaks. The pin must not detach from the steel sheet at the weld, but from slightly above. The weld must be stronger than the pin shaft.
- Repeat the test whenever the weld parameters change (pin type, steel thickness) or whenever there is a doubt about the weld quality based on sensory perceptions during welding.

NOTE: As certain conditions to achieve good weld are affected by the insulation product (points 4 and 5 below), it is recommended to perform this test with the insulation product and remove it before testing the weld quality by bending of pins.

Conditions to achieve good weld quality

1. Sharp tip of the pin; any flattening or radius of the tip must not exceed 0,5 mm.
2. Optimal setting of the welding machine
 - Voltage
 - Spring tension in the hand tool
3. Avoiding excess manual force on the pin during welding. There must be only light touch of the pin to the steel duct surface, and when the hand tool is triggered, the pin must only be pushed against the steel duct surface by the spring force in the hand tool.
4. Sufficient pin length so that there is minimum 3 mm clearance between the insulation surface and the pin head before welding.
5. Avoiding any stray currents and additional electrical resistance for the current flowing between the pin and the steel duct surface during the welding.
 - Place the negative electrode on the same duct segment where welding is performed.
 - Keep both electrodes clean and make sure there is good contact between the pin and the hand tool, and between the negative electrode clip and the duct surface.

PAROC SALES OFFICES AND CONTACTS

Headquarter / Finland

Paroc Group Oy / Paroc Oy Ab
P.O. Box 240
FI-00181 Helsinki, Finland
Energiakuja 3
Phone: +358 46 876 8000



Estonia

AS Paroc
Pärnu mnt 158
EE-11317 Tallinn, Estonia
Tel. +372 651 8100



Denmark

Paroc Danmark Filial af PAROC AB
Helsingør Erhvervspark A/S
H P Christensensvej 1
DK-3000 Helsingør
Tel. +45 49 12 10 00



Latvia

SIA Paroc
Vienības gatve 109
Rīga, LV-1058, Latvia
Tel. +371 7 339053



Germany / Switzerland / Austria

Paroc GmbH
Heidenkampsweg 51
D-20097 Hamburg, Germany
Tel. +49 40 33 49 60000



CONTACT US

Lithuania

UAB Paroc
Savanoriu 124
03153 Vilnius, Lithuania
Tel. +370 5 2740 000



Norway

Paroc AB Norge
Rosenholmveien 25
NO-1414 Trollåsen, Norway
Tel. +47 22 64 59 00 / 01



Poland

Paroc Polska sp. z o.o.
ul. Gnieźnińska 4
62-240 Trzemeszno, Poland
Tel. +48 61 468 21 90



Sweden

Paroc AB
SE-541 86 Skövde, Sweden
Visiting address: Bruksgatan 2
Tel. +46 500 469 000



The United Kingdom / Ireland

Owens Corning Insulation (UK) Ltd
31-35 Kirkby Street
London EC1N 8TE
The United Kingdom



CONTACT US

Disclaimer

Technical information contained herein is furnished without charge or obligation and is given and accepted at recipient's sole risk. Because conditions of use may vary and are beyond our control, Paroc makes no representation about, and is not responsible or liable for the accuracy or reliability of data associated with particular uses of any product described herein. Paroc reserves the right to modify this document without prior notice. PAROC is a registered trademark of Paroc Group Oy. This document is valid in the countries where the product is commercially available. Local requirements may apply.

March 2026
1275TIEN0326
© Paroc 2026

