

Fire insulation for load-bearing steel structures using Paroc Fire Protection Slab Paroc FPS 14

Applications

This method is intended to provide fire protection for load-bearing steel structures. The insulation can be installed on rolled or welded steel profiles with various cross-sections. Fire insulation is provided by Fire Protection Slab Paroc FPS 14, which is a non-combustible stone wool slab with excellent fire resistance. The insulation is installed in a single layer, with care being taken to ensure close contact at longitudinal and transverse joints. Insulation can be installed as shown in the main examples below.

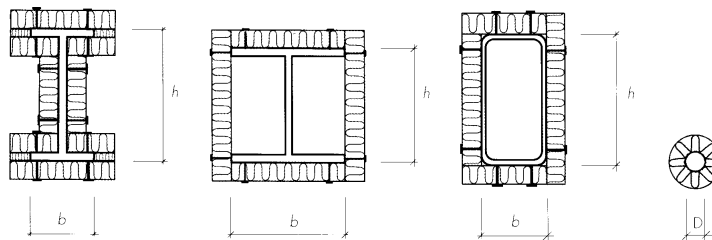

$$F = 4b + 2h$$



$$F = 2b + 2h$$

$$F = 2b + 2h \quad F = \pi \times D$$

Where I-beams have a web height greater than 1.0 metre the insulation must follow the contours of the steel surface.

Calculating insulation thickness

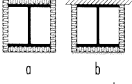
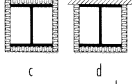
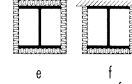
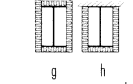
The required insulation thickness for various fire classifications (R30–R240) is determined using the design curves on pages 2 and 3. The input parameters are the permissible steel temperature and the profile ratio (F/A). The profile ratios for various steel profiles can be found in the respective manufacturer's specifications. For certain standard sizes the profile ratio may be found in the table below. F is calculated as shown in the schematic diagrams above. A is the cross-sectional area of the steel profile and represents the amount of steel that must be heated up.

HEA-profile		HEB-profile		HEM-profile		IPE-profile		Rektangular RHS-profile			Square RHS-profile								
																			
a b		c d		e f		g h		i i			k l								
F/A (m ²) F/A (m ²)		F/A (m ²) F/A (m ²)		F/A (m ²) F/A (m ²)		F/A (m ²) F/A (m ²)		BxHmm Wall thick mm F/A (m ²) F/A (m ²)			BxHmm Wall thick mm F/A (m ²) F/A (m ²)								
HE 100 A	184	138	HE 100 B	154	115	HE 100 M	85	65	IPE 80	330	270	100x50	3,2	328	274	40x40	3,2	343	258
HE 120 A	185	137	HE 120 B	141	106	HE 120 M	80	61	IPE 100	300	247	100x50	4	266	221	40x40	4	282	211
HE 140 A	174	129	HE 140 B	130	98	HE 140 M	76	58	IPE 120	279	230	100x60	3,6	294	238	60x60	3,2	332	249
HE 160 A	161	120	HE 160 B	118	89	HE 160 M	71	54	IPE 140	259	215	100x60	5	215	175	60x60	4	270	203
HE 180 A	155	115	HE 180 B	110	83	HE 180 M	68	52	IPE 160	241	200	120x60	3,6	290	242	80x80	3,6	294	220
HE 200 A	145	108	HE 200 B	103	77	HE 200 M	65	49	IPE 180	226	188	120x60	5	213	178	80x80	5	215	161
HE 220 A	134	100	HE 220 B	97	73	HE 220 M	62	47	IPE 200	211	176	120x80	5	212	169	100x100	5	212	159
HE 240 A	122	91	HE 240 B	91	68	HE 240 M	52	40	IPE 220	198	165	120x80	8	138	110	100x100	8	138	103
HE 260 A	118	88	HE 260 B	88	66	HE 260 M	51	39	IPE 240	184	153	150x100	5	209	167	120x120	5	210	157
HE 280 A	113	84	HE 280 B	85	64	HE 280 M	50	38	IPE 270	176	147	150x100	8	135	108	120x120	8	135	101
HE 300 A	105	78	HE 300 B	81	60	HE 300 M	43	33	IPE 300	167	139	160x80	5	210	175	150x150	6,3	167	125
HE 320 A	98	74	HE 320 B	77	58				IPE 330	156	131	160x80	8	135	113	150x150	12,5	88	66
HE 340 A	94	72	HE 340 B	75	57				IPE 360	146	122	200x100	5	208	173	180x180	6,3	165	124
HE 360 A	91	70	HE 360 B	73	57				IPE 400	137	116	200x100	10	108	90	180x180	12,5	87	65
HE 400 A	87	68	HE 400 B	71	56				IPE 450	130	110	250x150	6,3	165	134	200x200	6,3	165	124
HE 450 A	83	66	HE 450 B	69	55				IPE 500	121	104	250x150	12,5	86	70	200x200	12,5	86	65
HE 500 A	80	65	HE 500 B	67	55				IPE 550	113	98	300x200	6,3	163	131	250x250	6,3	163	123
HE 550 A	79	65	HE 550 B	67	55				IPE 600	105	91	300x200	12,5	85	68	250x250	12,5	85	64
HE 600 A	79	65	HE 600 B	67	56										300x300	10	103	78	
HE 650 A	79	65	HE 650 B	66	56										300x300	12,5	84	63	

CALCULATING INSULATION THICKNESS

The insulation thickness is determined using the design curves below. The input parameters are the permissible steel temperature and the profile ratio (F/A). For certain standard sizes the profile ratio may be found in the table.

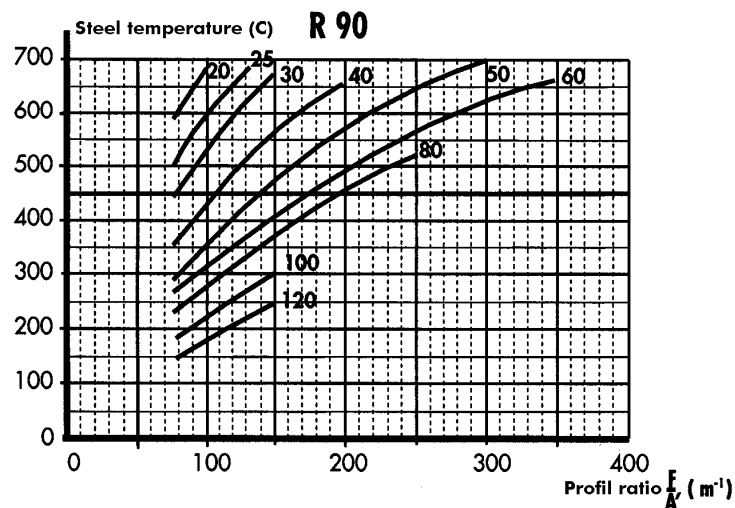
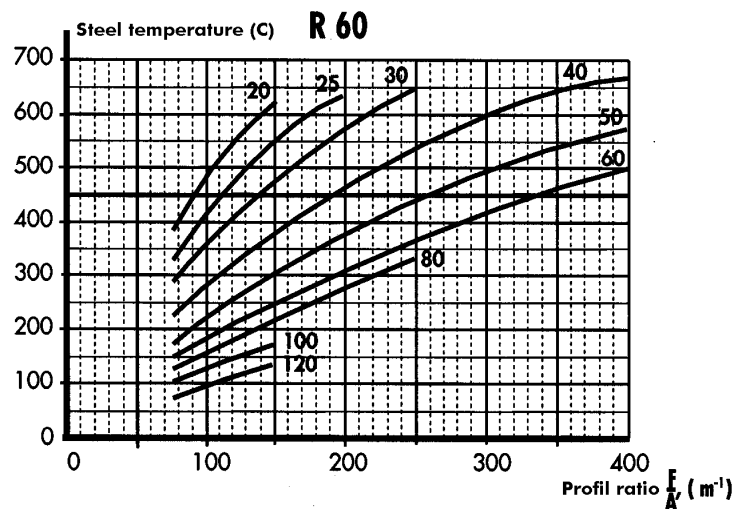
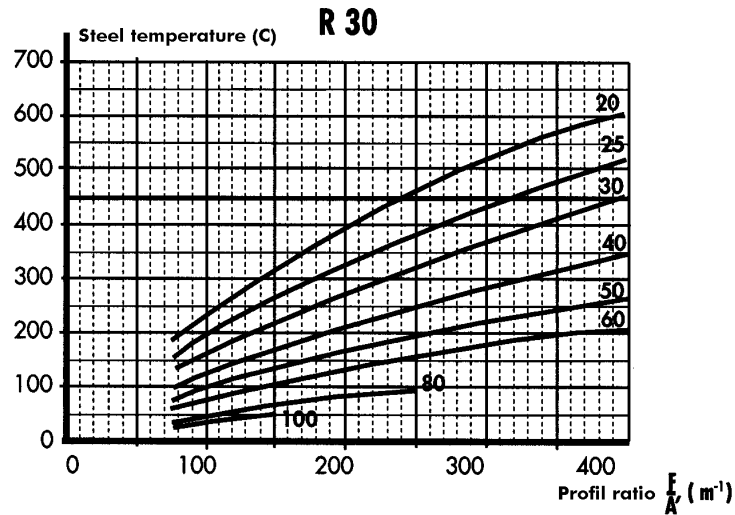

CALCULATING INSULATION THICKNESS

The insulation thickness is determined using the design curves below. The input parameters are the permissible steel temperature and the profile ratio (F/A). For certain standard sizes the profile ratio may be found in the table.

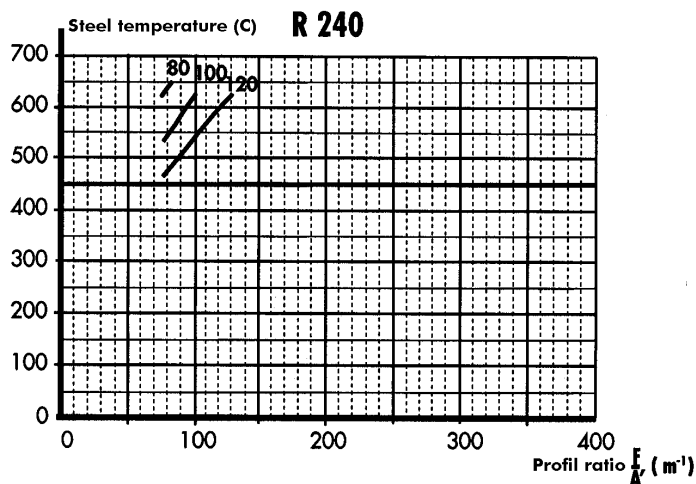
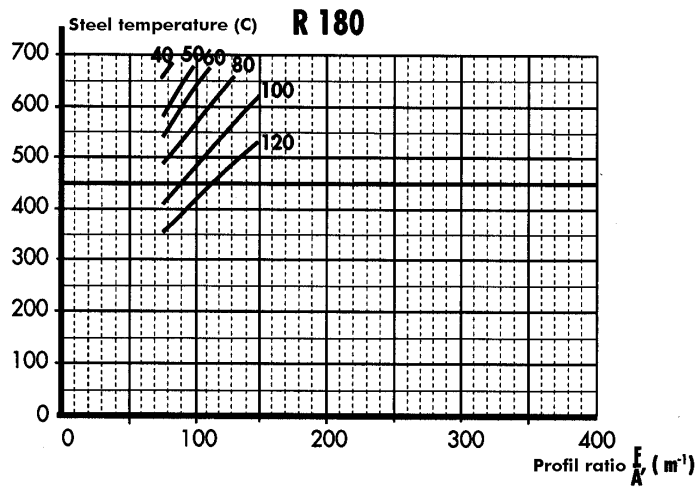
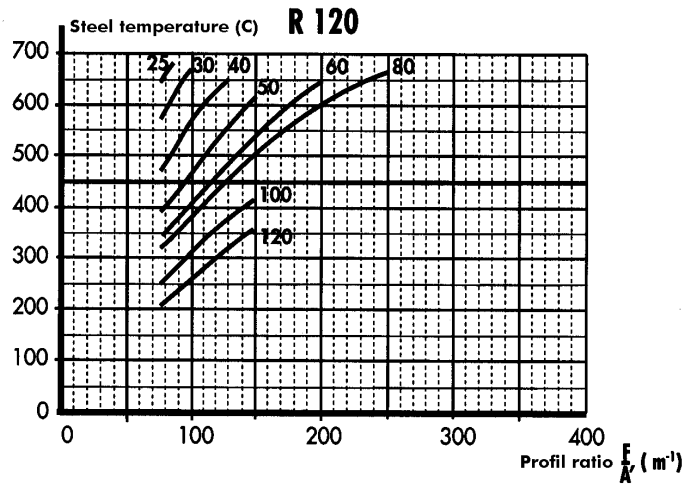

Installation

There are three alternative methods for fixing fire insulation:

Stud-welding, nailing or screwing.

Welding

The insulation is fixed using steel studs and washers. The steel studs must be at least 3 mm in diameter. The length after welding must be 2–3 mm greater than the insulation thickness. The studs are attached using special stud-welding equipment and positioned on the steel profile as shown in the schematic diagrams below. For information on operating the welding equipment refer to the relevant manufacturer's instructions. At least 10 studs should be used per square metre of insulation.

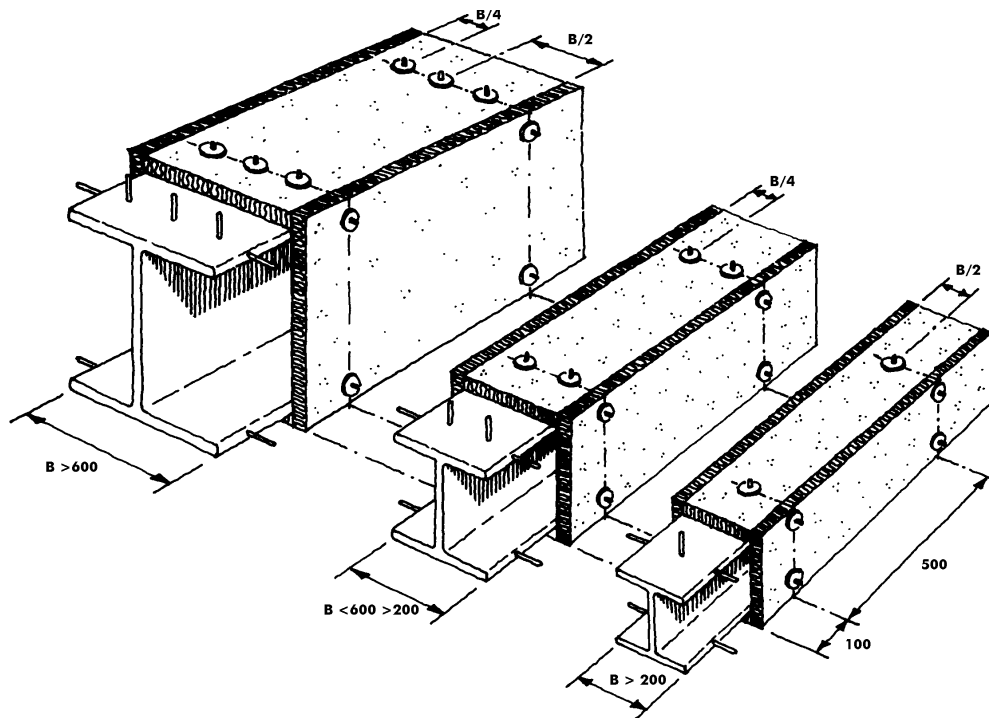

When the insulation is fixed onto a steel surface (e.g. a flange) the studs nearest the joints in the insulation must be no more than 100 mm from the joint. If the breadth of the flat steel surface (B) is less than or equal to 200 mm then a single line of studs must be attached along the centre line of the face. A normal coating of rust on the face of the profile will not pose any installation problems. If the profile has been finished with corrosion-resistant paint this must be removed around the areas to be welded, with the aid an electric drill and abrasive wheel, for example. The insulation slab is pressed onto the steel studs and secured with steel locking washers. The fixing washers must have a contact area of at least 7 cm² (minimum diameter 35 mm).

Nailing

The insulation is fixed using steel nails and washers. The steel nails are shot into the steel profile using a Hilti nail gun or similar equipment. For information on operating this equipment refer to the relevant manufacturer's instructions. The size and positioning of the nails are the same as already described for stud-welding. The steel thickness must be at least 12 mm before this method can be used. The steel surface does not require any special cleaning.

Screwing

The insulation is fixed using special screws. The first stage of installation is to push 100-mm wide pieces of Fire Protection Slab Paroc FPS 14 between the flanges of the steel profile, with a maximum centre-to-centre spacing of 600 mm. The thickness of the slab must be at least 40 mm. If the height of the beam is greater than 400 mm a piece of slab must be placed edge-on between the insulation and web to provide additional support. If the breadth is greater than 300 mm then 3-mm pins or studs must be nailed or welded to the centre line of the flange at 300-mm intervals.

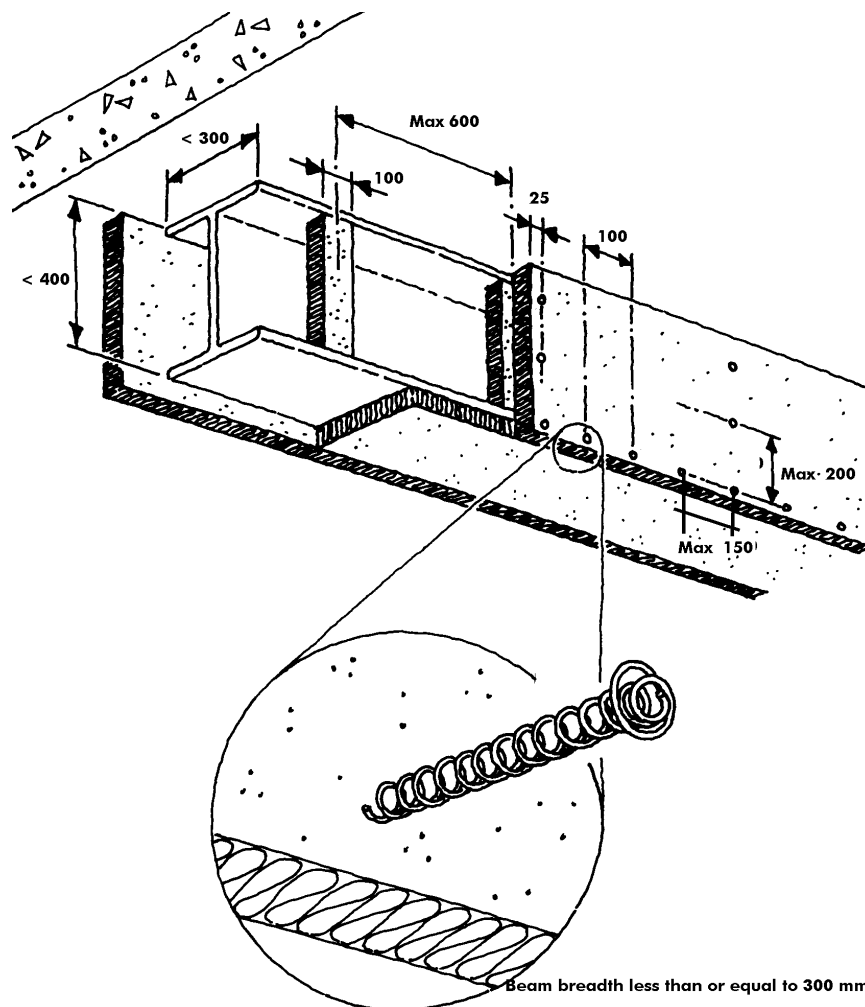

Cont.

Cut the insulation so that it is equal to the height of the beam, plus the thickness of the flange insulation. At least two bolts are required at intervals of 200 mm or less. The spacing between the bolts is shown in the diagram below. It is recommended that the bolt length is twice the insulation thickness. Insulation should be fixed to the top of RHS profiles by butt-welding or nailing. The steel pins or studs are fixed at intervals of less than 500 mm, and less than 100 mm from joints in the insulation.

